

P 1000



PP



PVDF+CF



ALU



SS

TECHNICAL DATA

| | |
|--------------------------|----------------------|
| Fluid connections | 3" BSPP-DN 80 |
| Air connection | 3/4" BSPP |
| Max. Flow rate | 1050 lt/min |
| Max air pressure | 8 bar |
| Max delivery head | 80 m |
| Max Suction Lift Dry | 5 m |
| Max Suction Lift Wet | 9,8 m |
| Max Solid passing | 12 mm |
| Noise level: | 82 dB |
| Max Viscosity: | 55.000 cps |
| Displacement per Stroke: | 9750 CC ~ |

Ⓜ II 3/3 G Ex h IIB T4 Gc
 Ⓜ II 3 D Ex h IIB T135°C Dc X

Displacement per stroke may vary based on suction condition, discharge head, air pressure and fluid type.

PERFORMANCE

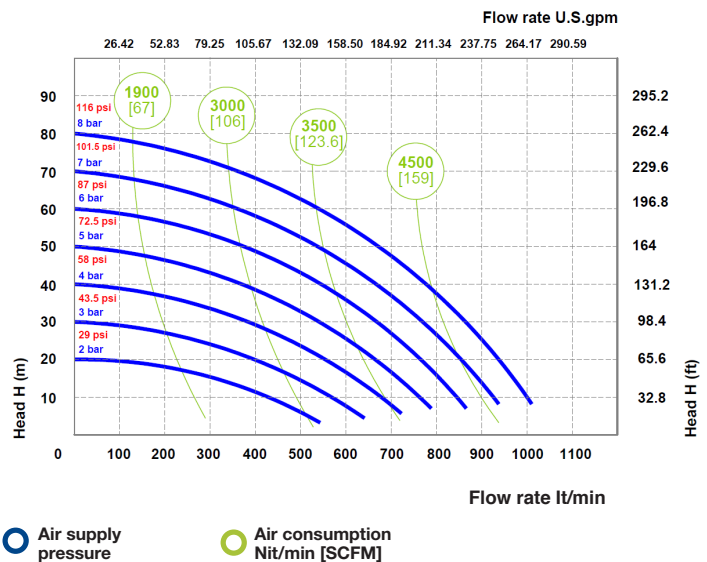

⊙ Air supply pressure ⊙ Air consumption Nit/min [SCFM]

The curves and performance values refer to pumps with submerged suction and a free delivery outlet with water at 20°C. These data may vary according to the construction materials and hydraulic conditions.

DIMENSIONS

| | A | B | C | Net Weight | Temperature |
|------|--------|--------|----------|------------|-------------------|
| PP | 780 mm | 417 mm | 1024 mm | 62 kg | - 4 °C + 65 °C |
| PVDF | 780 mm | 417 mm | 1024 mm | 77 kg | - 20 °C + 95 °C |
| ALU | 710 mm | 417 mm | 940 mm | 84 kg | - 20 °C + 95 °C |
| SS | 672 mm | 417 mm | 946,5 mm | 122 kg | - 20 °C + 95 °C |

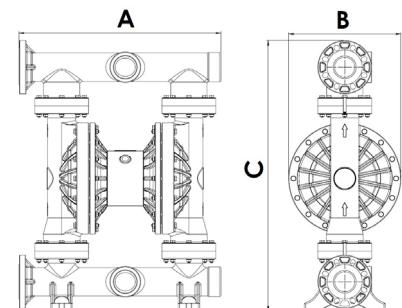

COMPOSITION

| MODEL | CASING | DIAPHRAGM | BALLS | SEATS | GASKET | CONNECTIONS | ATEX | PORTS |
|--------------|---|--|---|--|--|-----------------------------------|------------|---------------|
| P1000 | P = PP KC = PVDF+CF S = SS A = ALU | HT = HYTREL+PTFE MT = SANTOPRENE+PTFE H = HYTREL W = SANTOPRENE H.R. D = EPDM N = NBR | T = PTFE S = SS D = EPDM N = NBR | P = PP K = PVDF S = SS Z = PE-UHMWE | D = EPDM V = VITON N = NBR T = PTFE | 1 = BSP 2 = FLANGED 5 = NPT | - = zone 2 | AB = STANDARD |